



Data Sheet No:	160101-650 OUTBOARD
Product Type:	RHIB
Product Designation:	650 PATROL



Design Classification:	ISO 12215-5 Design Cat B	Propulsion:	Outboard Motor
Hull Material:	Composite (GRP)	Max Draft:	0.45m
Length Overall:	6.50 m	Fuel type:	Petrol
Beam Overall:	2.45 m	Fuel capacity:	Up to 150 litres
Collar Type:	Inflatable / Hybrid	Weight (100% fuel):	1300 kg depending on options
Collar Diameter:	0.50 m	Crew Seating:	Up to 6
Lifting/Launching:	4-Point Lifting sling Single Point Lift Stern Ramp	Maximum Payload:	750 kg
Power:	Up to 270 hp	Max Speed:	Up to 40 knots
		Range:	Up to 120 nm
		Navigation:	GPS/Radar/Echo



© Marine Specialised Technology Limited 2012

<p>MARINE SPECIALISED TECHNOLOGY LIMITED Unit 2 Atlantic Way, Brunswick Business Park, Liverpool, Merseyside, L3 4BE, United Kingdom Phone: +44 (0)151 708 4112 Fax: 44 (0)151 708 4113 Email: sales@mstltd.com Web: www.mstltd.com</p>
--

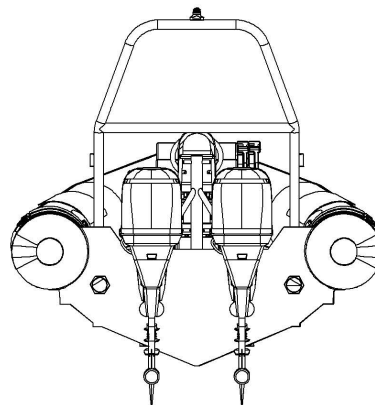
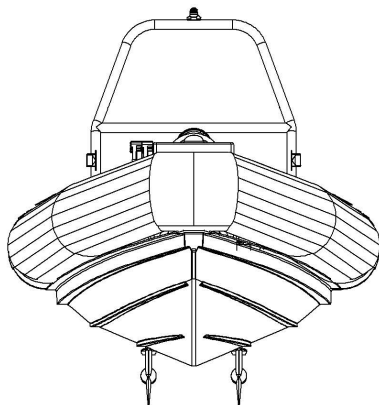
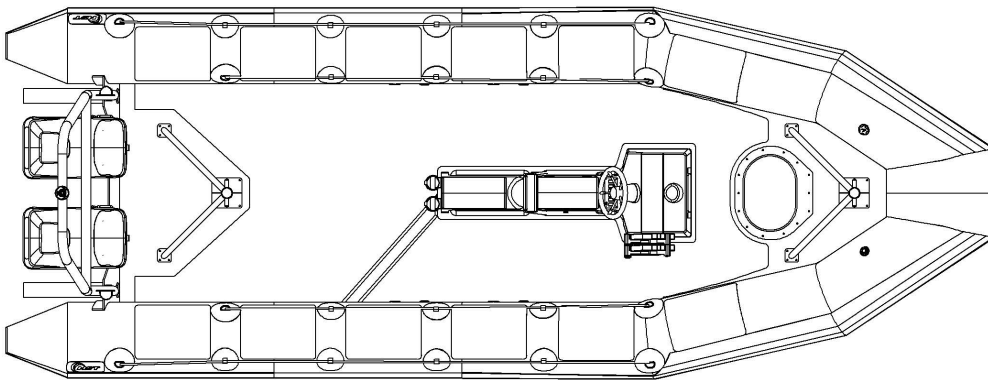
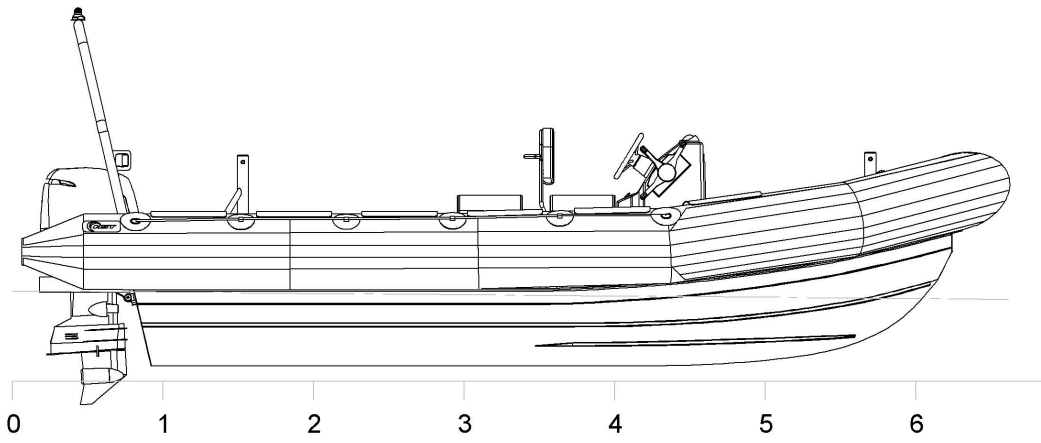

MARINE SPECIALISED TECHNOLOGY LIMITED

Unit 2 Atlantic Way, Brunswick Business Park, Liverpool, Merseyside, L3 4BE, United Kingdom
Phone: +44 (0)151 708 4112 Fax: 44 (0)151 708 4113 Email: sales@mstltd.com Web: www.mstltd.com